

 Denver Instrument Company

BASIC pH Meter

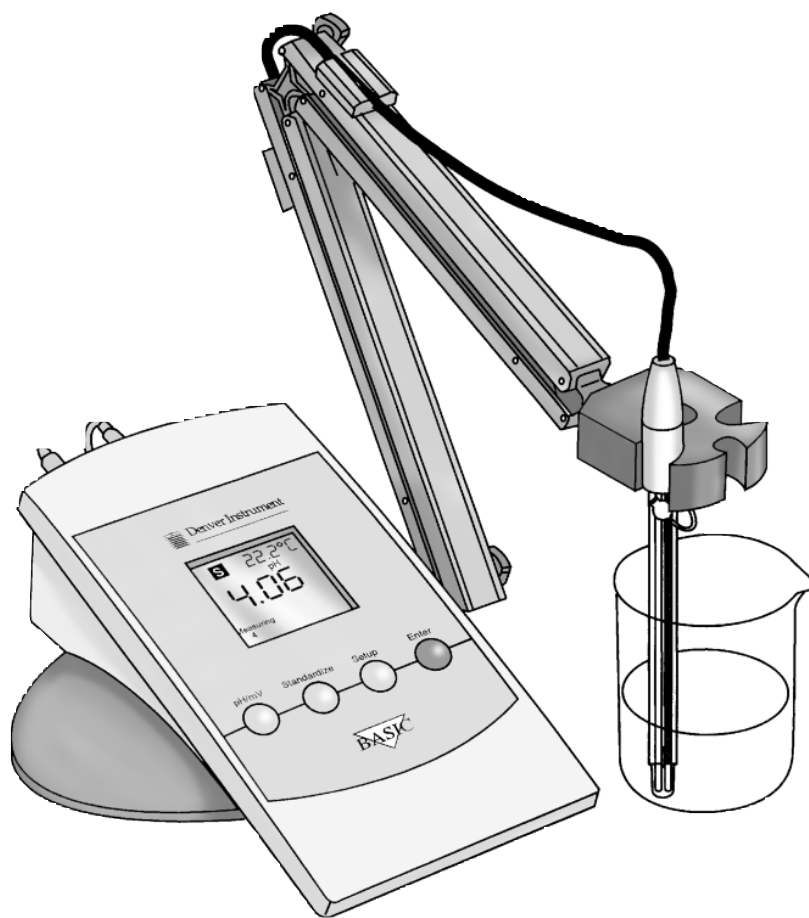

Operation Manual

300408.1 Rev. G

BASIC pH Meter Quick Reference

1. Connect power cable to meter power jack and to AC power source.

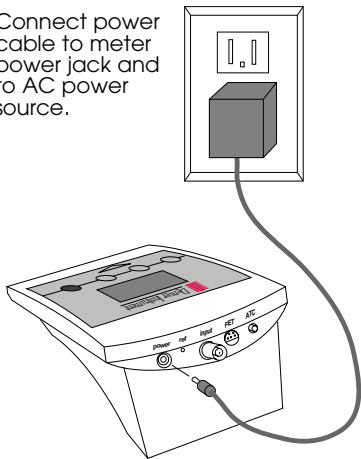

2. Connect a glass pH electrode to the input and ATC connectors, **or** connect the FET pH electrode to the FET connector.

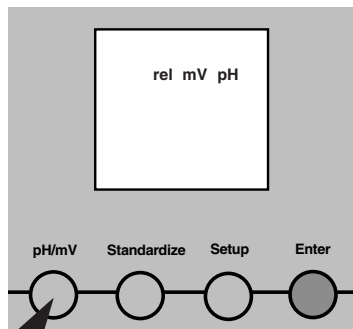
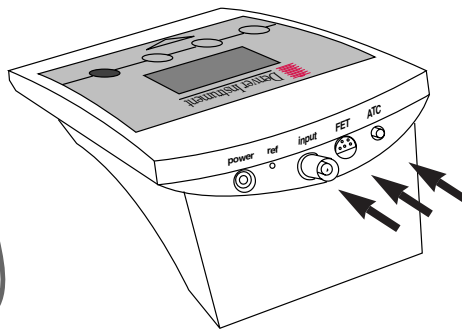

3. Press **pH/mV** until the display indicates the appropriate measurement mode (pH or mV/relative mV).

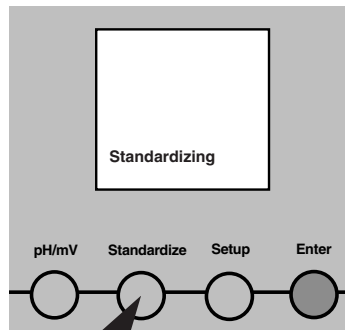

4. Standardize the meter using up to three buffers by immersing the electrode in a buffer, stirring, then pressing **Standardize** to enter each buffer.

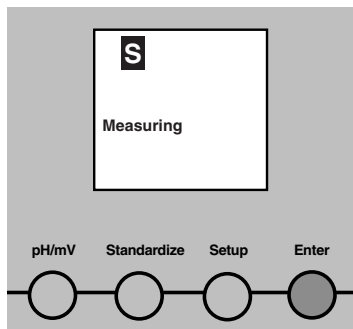

5. The display shows the current reading in pH, mV, or relative mV units.

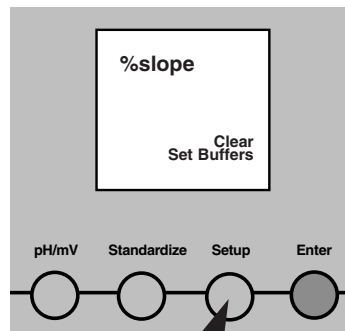

6. Press **Setup** to review electrode calibration and to clear or select buffer sets.

Table Of Contents

Quick Reference	Inside Front Cover
Getting Started	
Front panel controls	3
Digital display	3
Rear panel connectors	4
Connecting to a power source	4
Installing and Maintaining Electrodes	5
Preparing glass electrodes	5
Installing the combination glass pH electrode	5
Installing the FET pH electrode	6
Installing ORP or ISE electrodes	6
Rinsing electrodes	7
Storing electrodes	7
Standardizing for pH Measurement	8
Entering buffers	8
The diagnostic electrode test	9
Selecting buffers based on 20°C or 25°C	11
Using Setup	11
Clearing Buffers	11
Reviewing electrode standardization	11
Selecting buffer sets	11
Standardizing for Millivolt Measurement	
(Relative Millivolts)	13
Entering a millivolt standard	13
Clearing a millivolt standard	14
Measuring pH or Millivolts	14
Understanding pH Theory	15
Defining pH	16
Measuring pH	17
Troubleshooting	18
The "Error" Icon	18
The "CAL Error" Icon	18
The "Err °C" Icon	18
The "Electrode Error" Icon	18
Electrode testing	18
Meter Operation testing	18
Meter Specifications	20
Accessories	20
Technical Assistance	Back Cover



The **CE** marking affixed to the equipment indicates that the equipment meets the requirements of the following Directive(s).

Council Directive 809/336/EEC “Electromagnetic compatibility (EMC)”

EN-61010-1, “SAFETY REQUIREMENTS FOR ELECTRICAL EQUIPMENT FOR MEASUREMENT, CONTROL, AND LABORATORY USE. PART 1. GENERAL REQUIREMENTS”

Applicable European Standards:

EN-55011 ELECTROMAGNETIC EMISSION REQUIREMENTS FOR ISM

Defined immunity to interference:

EN 50082-1 Residential, commercial and light industry

Important Note:

The operator shall be responsible for any modifications to Denver Instrument Company equipment and for any connections of cables or equipment not supplied by Denver Instrument and must check and if necessary, correct these modifications and connections. On request, Denver Instrument Company will provide information on the minimum operating specifications (in accordance with the Standards listed above for defined immunity to interference).

You have purchased a quality precision meter that requires handling with care.

*Read entire contents of this **Operation Manual** prior to operating your new Denver Instrument meter.*

Caution:

Changes or modifications not expressly approved by the manufacturer could void the product’s warranty.

Manufactured in the U.S.A. by:



Denver Instrument Company

6542 Fig Street • Arvada, Colorado 80004
(303) 431-7255 • (800) 321-1135 • Fax(303) 423-4831

Getting Started

Front Panel Controls

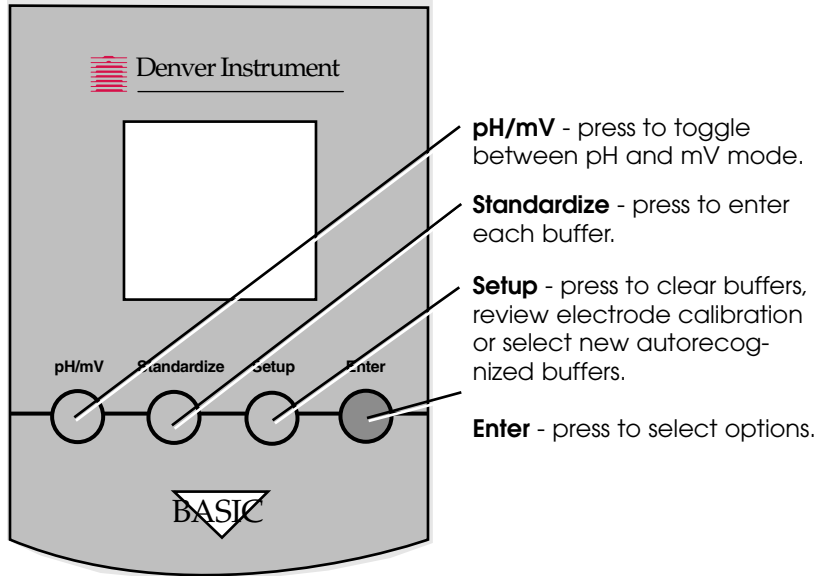

Digital Display

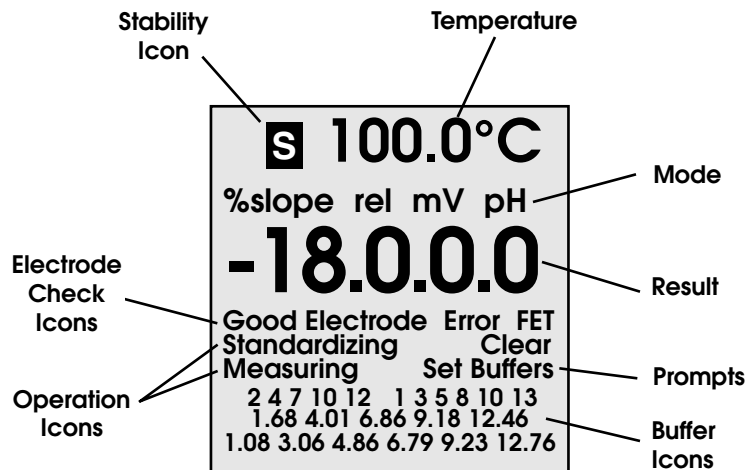

Rear Panel Connectors

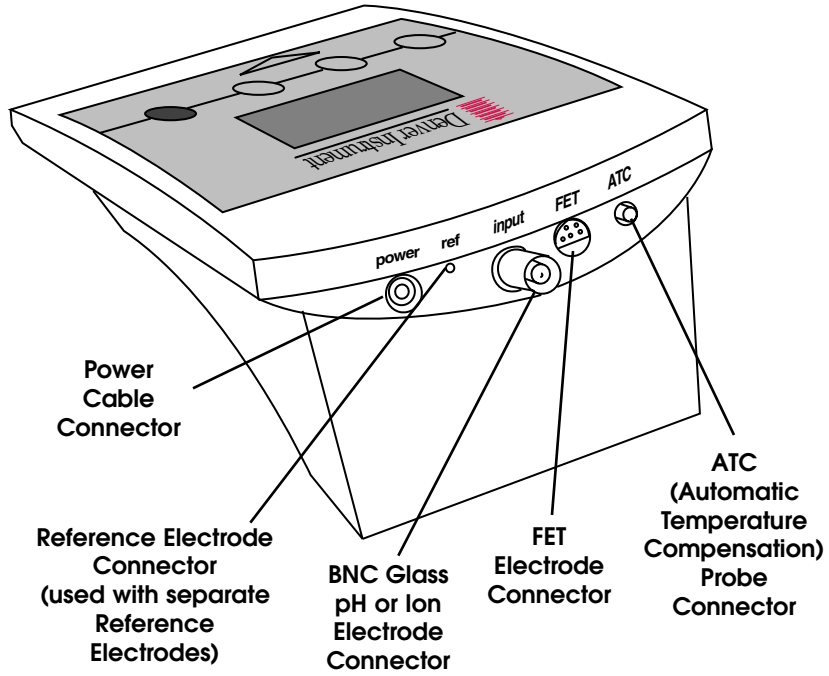

Connecting to a Power Source

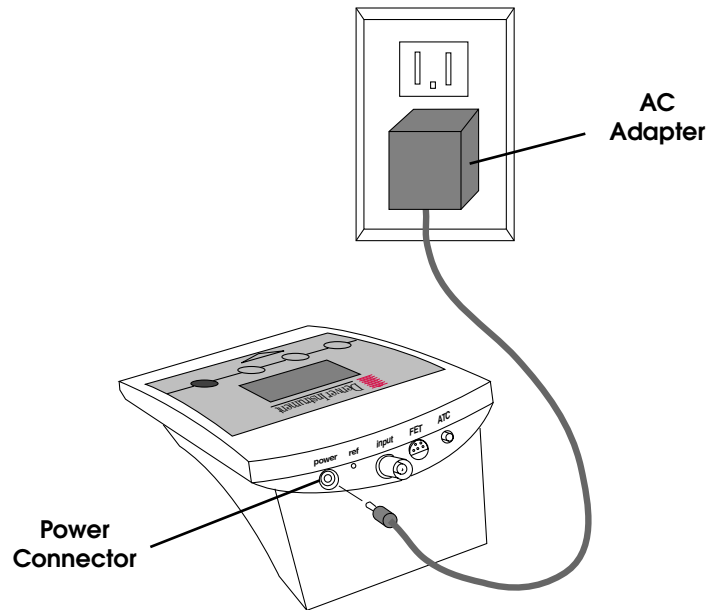

Installing and Maintaining Electrodes

This meter allows you to use two types of pH electrodes: a glass pH electrode and the Denver Instrument FET (field effect transistor) pH/ATC electrode. If both types of electrodes are installed, the meter will read the FET electrode. **NOTE: If both electrodes are connected to the meter, do not put them in a solution together because you will get inaccurate measurements.**

1. Remove the protective end cover from electrode.

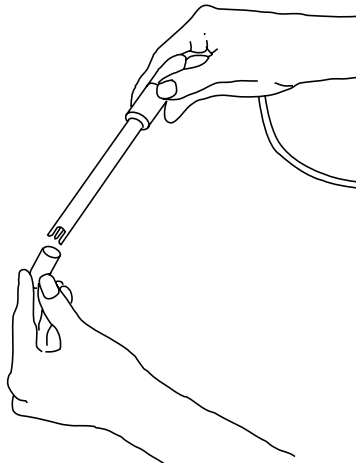

2. Before first use of your glass pH electrode, or whenever the electrode is dry, soak overnight in an Electrode Filling Solution, KCl solution or Electrode Storage Solution.

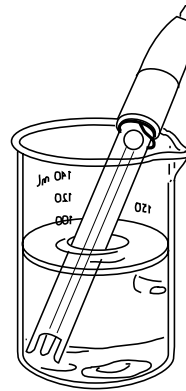

3. Remove the shorting cap on the BNC connector. Install the combination glass pH/ATC electrode by plugging it into the **input** connection (push on and twist to lock) and the ATC connector into the **ATC** jack.

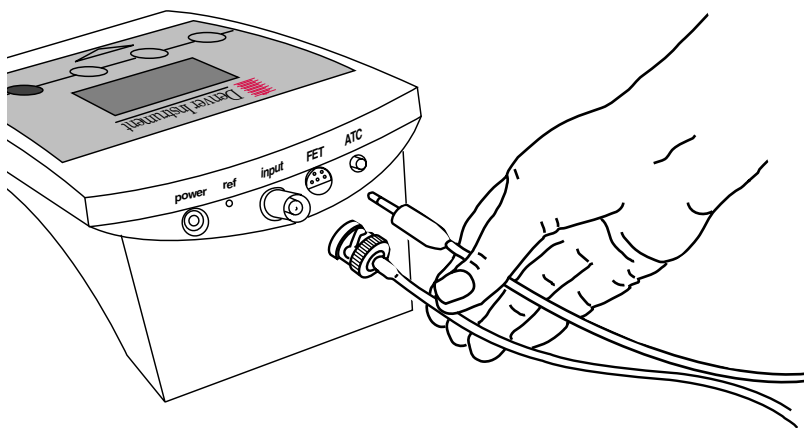

4. *Option:* Install the optional FET pH/ATC electrode by plugging it into the **FET** jack on the back of the meter panel. Allow the FET electrode to stabilize for one minute prior to use.

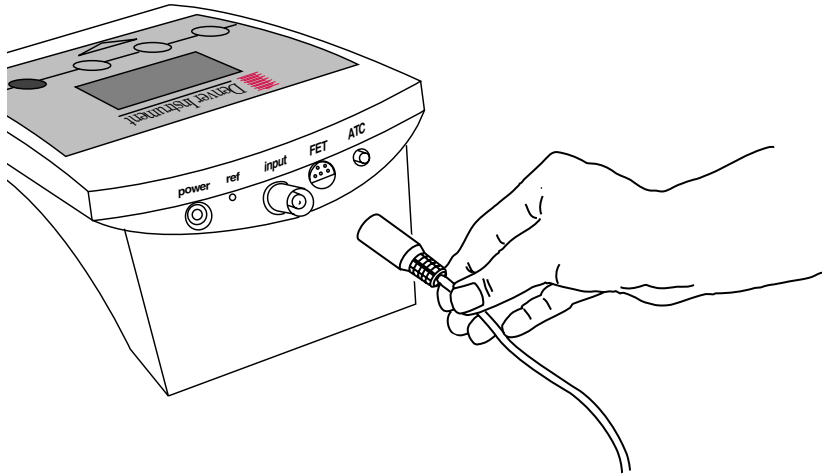

5. *Option:* Install ORP or Ion Selective Electrode pairs by removing the BNC shorting cap and plugging the BNC connector (twist-lock) into the BNC jack. If a separate reference electrode is used, plug the reference electrode into the **ref** pin.

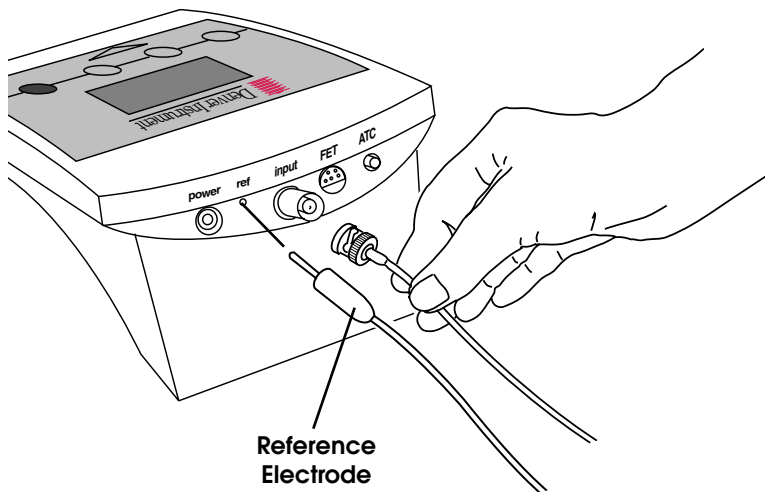

6. Rinse and blot-dry electrodes between each measurement (**do not wipe**). Rinse electrodes with distilled water or deionized water, or part of the next solution to be measured.

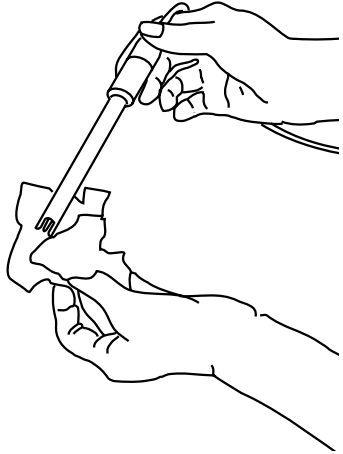

7. Store glass pH electrodes in Electrode Filling Solution, KCl solution or Electrode Storage Solution. Always leave the filling hole open and refill with Filling Solution when the internal solution level gets low. Store FET pH/ATC electrodes dry.

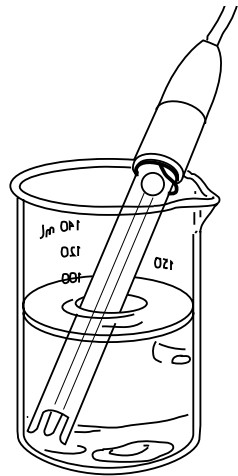

Standardizing for pH Measurement

Because electrodes vary in their response, you must standardize your pH meter and electrode to compensate for electrode variation. The more frequently you standardize, the more accurate your measurements. Standardize daily, or more often, for accurate results.

1. Immerse electrode in a buffer solution. Stir gently. Allow the electrode to reach a stable value.
2. Press and release the **pH/mV** button until your digital display indicates pH mode. This button toggles between pH and mV modes.

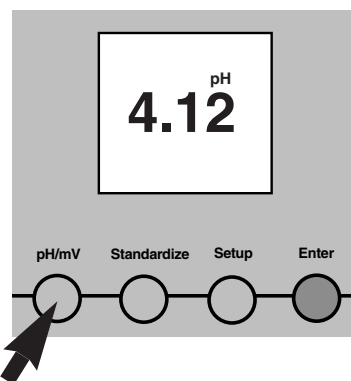
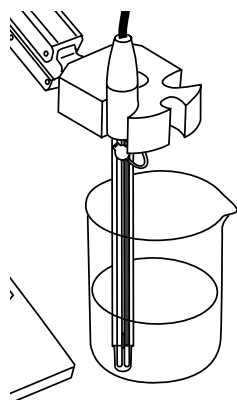

3. Clear existing buffers when doing a new 2 or 3 point standardization. Use the **Setup** and **Enter** buttons to clear existing buffers and to select a new set of buffers. See page 11.
4. Press **Standardize**. The meter recognizes the buffer and flashes a buffer icon. When the signal is stable, or when you press **Enter**, the buffer is entered.

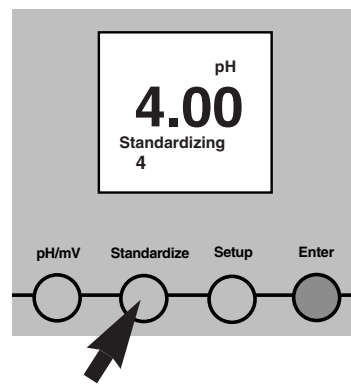
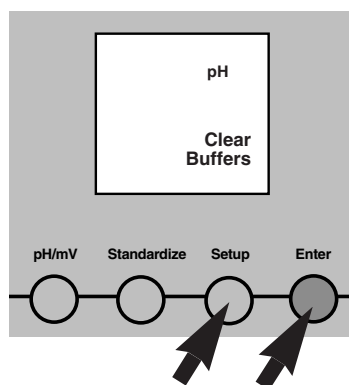

5. The meter displays the %slope of the electrode as 100.0%. On entering a second or third buffer, the meter performs a diagnostic check on the electrode and displays the slope.

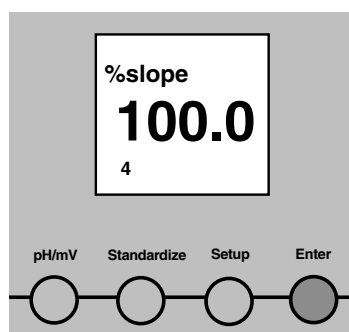

6. To enter a second buffer, place the electrode in the second buffer solution, stir, allow time for the electrode to stabilize, and press **Standardize** again. The meter recognizes the buffer and displays the first and second buffer icons.

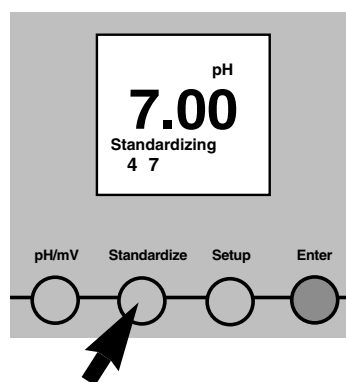

7. Next, the meter performs a diagnostic test of the electrode. The display indicates either **Good Electrode** or **Electrode Error**. The meter displays the % slope of the electrode.

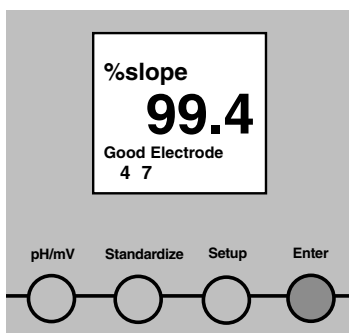

8. **Electrode Error** indicates that your electrode is not working properly. The electrode response must be between 90 and 105% slope. Measurements causing Electrode Error are not accepted, used or stored by the meter. Press Enter to clear the Error, then try re-entering the buffer.

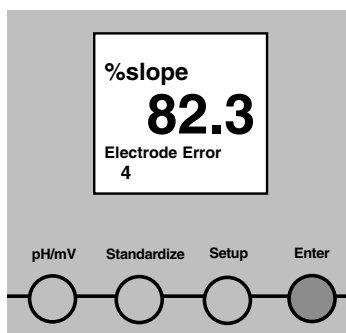

9. To set a third standard, place the electrode in the third buffer solution, stir, allow to stabilize, and press **Standardize**. The results will be the same as in steps 7 and 8, except the display will show three buffer icons.

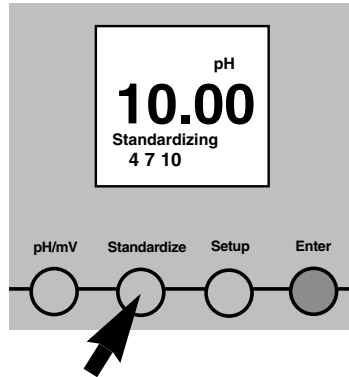

10. After entering each buffer, the *Standardizing* icon goes off and the *Measuring* icon appears on the display to indicate that the meter returns to *Measuring* operation.

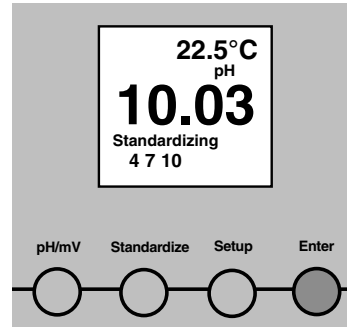

NOTE: The meter continually adjusts for temperature. Therefore, buffers may vary slightly from the nominal values because of temperature.

11. Standardize your meter and electrode using at least two buffers with pH values bracketing the expected pH of your samples. Stirring with a magnetic stir bar and stirrer provides faster electrode response.

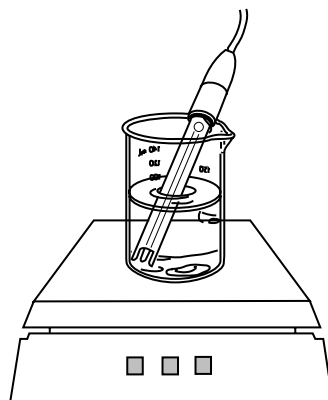

12. The first set of buffers in the meter is used at 25°C in North America and, typically, at 20°C in Europe. In pH mode, press **Standardize** and **Setup** together to show the current buffer temperature setting. Press both **Standardize** and **Setup** again to toggle between the temperature settings. Press **Enter** to select the displayed temperature setting and to return to *Measuring*.

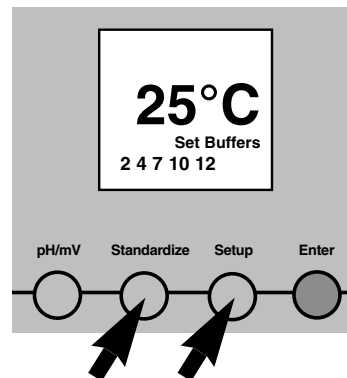

Using Setup

The **Setup** button lets you clear all the buffers that you have entered, review calibration information, or select the buffer set that you want. *NOTE: You can escape setup mode at any time by pressing **pH/mV**.*

1. Press **Setup** and the meter displays a flashing *Clear Buffers* icon. Use this step only when you wish to clear all buffers you have entered. To clear all existing buffers, press **Enter**. The meter clears all buffers and returns to *Measuring*.
2. Press **Setup** again to show electrode performance. If the meter has accepted two buffers, it will display *Good Electrode*, display the slope between the first and second buffers and display the two buffer icons.

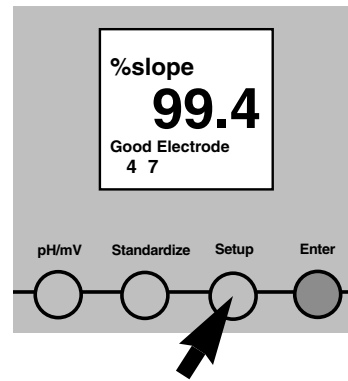
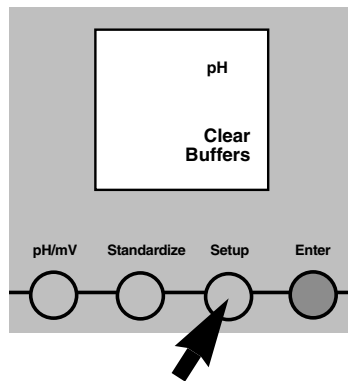

3. Pressing **Setup** again shows the electrode slope between the second and third buffers (if three buffers have been entered) and shows the second and third buffer icons.
4. Press **Setup** again to display a flashing *Set Buffers* icon and to display the first buffer set icons.

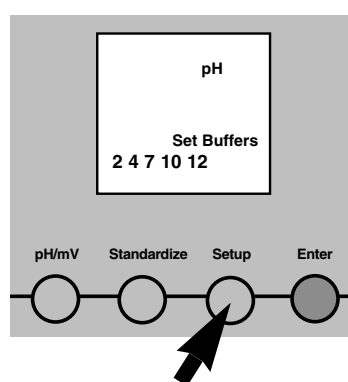
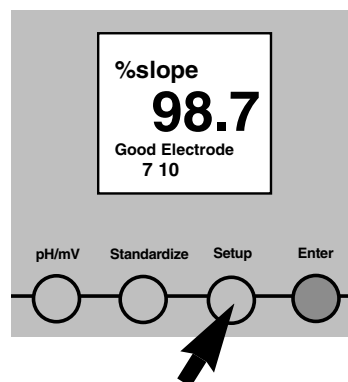

5. Press **Enter** to select the set of buffers shown on the display
or
Press **Setup** again to view the next set of buffers. Continue pressing Setup to view the third and fourth buffer sets.

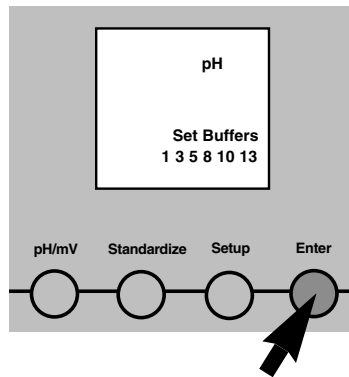

6. Press **Enter** to select the displayed buffer set that contains the buffer you want to use. Press **Setup** again, or press pH/mV at any time, to return to *Measuring*.

NOTE: You may mix buffers from different sets.

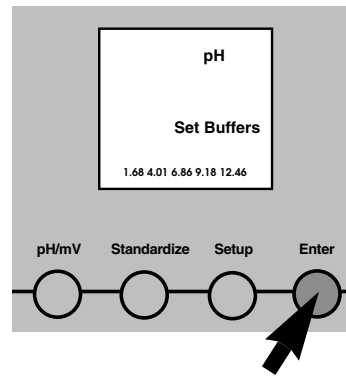

Standardizing for Millivolt Measurement (Relative Millivolts)

You use millivolt measurement for measuring ion concentration and for measuring redox potential (also called ORP, oxidation reduction potential). You will normally use an ion selective electrode (ISE), combined with a reference electrode, to measure ion concentration. The ISE senses the ion concentration and responds with a millivolt potential. The millivolt readings are then used to determine ion concentrations. You will normally use a platinum indicator electrode, combined with a reference electrode, to measure redox potential (ORP). ORP measurements indicate the oxidizing or reducing capability of a solution. You can use ORP values to monitor or control solutions requiring a set amount of oxidants or reductants.

1. Immerse electrode in a standard solution.

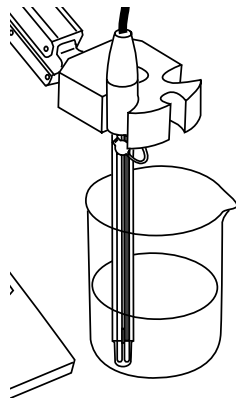

2. Press the **pH/mV** button until your digital display indicates mV mode.

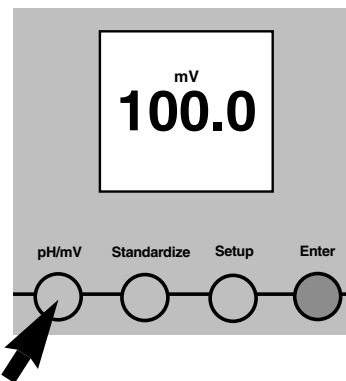

3. Press **Standardize** to enter a mV standard and read relative mV.

NOTE: Relative mV mode is not allowed with the FET electrode.

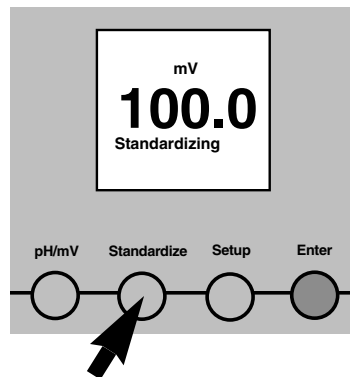

4. When the signal becomes stable, or when you press **Enter**, the current absolute mV value becomes zero relative millivolts.

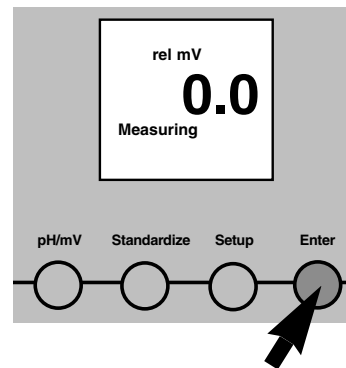

5. To clear a mV offset and return to absolute millivolt mode, press **Setup**. The meter displays a flashing *Clear* icon, and shows the current relative millivolt offset.

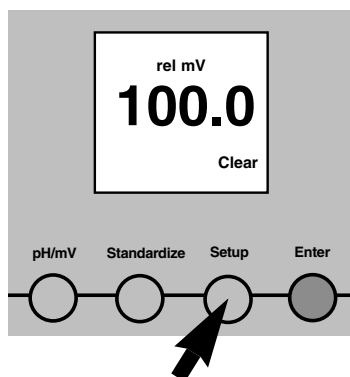

6. To clear the mV standard, press **Enter**. You then return to absolute mV mode.

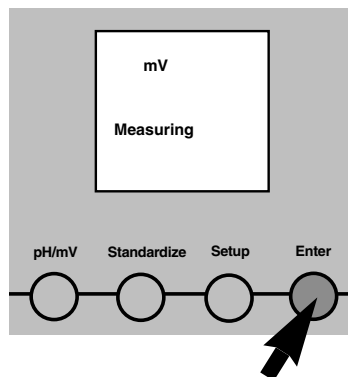

Measuring pH or Millivolts

1. Standardize your meter.
See page 10 (pH) or page 15 (mV).

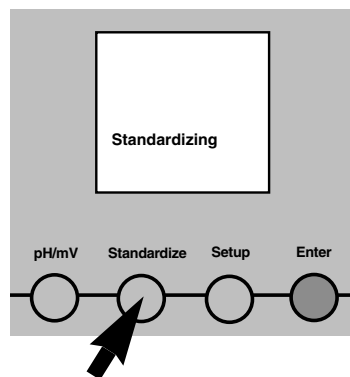

2. Rinse electrode and immerse in sample solution. Stir gently.

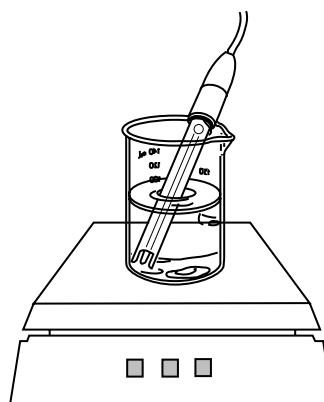

3. Press **pH/mV** until your display indicates the correct mode.

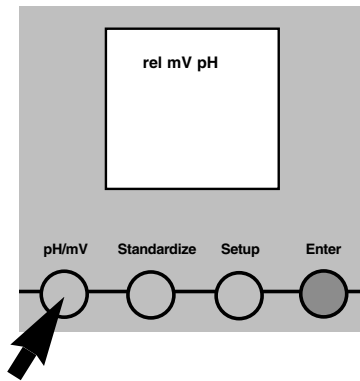

4. The display shows the current reading in pH, mV, or relative mV units. When the signal is stable, the meter displays the **S** icon. The **S** icon means the signal is changing less than 0.007 pH or 0.08 mV from the prior reading.

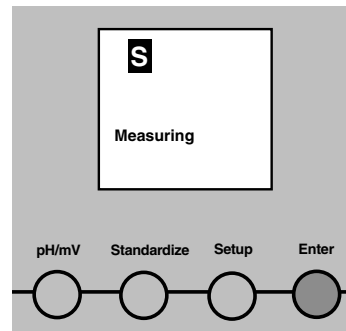

5. You may receive an out of range error, **Err**, if your electrode is not immersed in a solution. To correct the error, immerse the electrode in a solution.

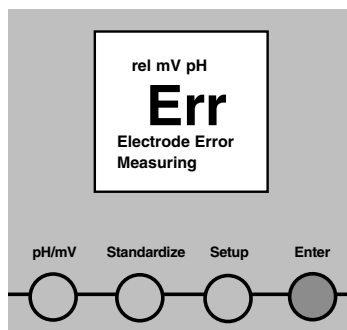

6. Separate calibrations for the glass and FET electrodes are stored in memory. Plugging the FET in recalls its calibration, unplugging the FET recalls the glass electrode calibration.

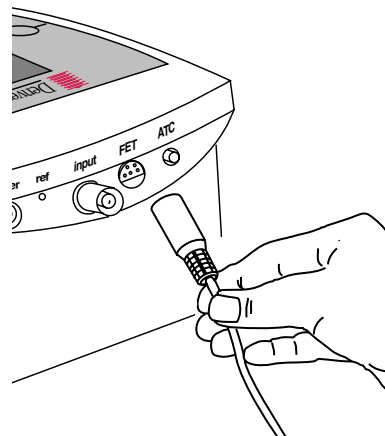

Understanding pH Theory

Defining pH

The measurement of pH plays an important role in identifying and controlling acidity and alkalinity levels for industry and research. pH is a measure of the acidity or alkalinity of a solution and can be represented by this equation:

$$\text{pH} = -\log [\text{H}^+]$$

with $[\text{H}^+]$ representing the concentration of hydrogen ions in the solution. pH is sometimes referred to as the power of the hydrogen ion in a solution.

By using a pH meter, you can determine exact pH levels of solutions. For example, rather than say that lemon juice is quite acidic, you can say that lemon juice has a pH of 2.4. An exact pH value can be used to control or measure acidity levels for manufacturing processes or for basic research.

pH values generally range from 0 to 14, with a pH value of 7 being the neutral point, or the value of pure water. pH values greater than 7 represent increasing alkalinity, whereas pH values below 7 represent increasing acidity (Figure 1).

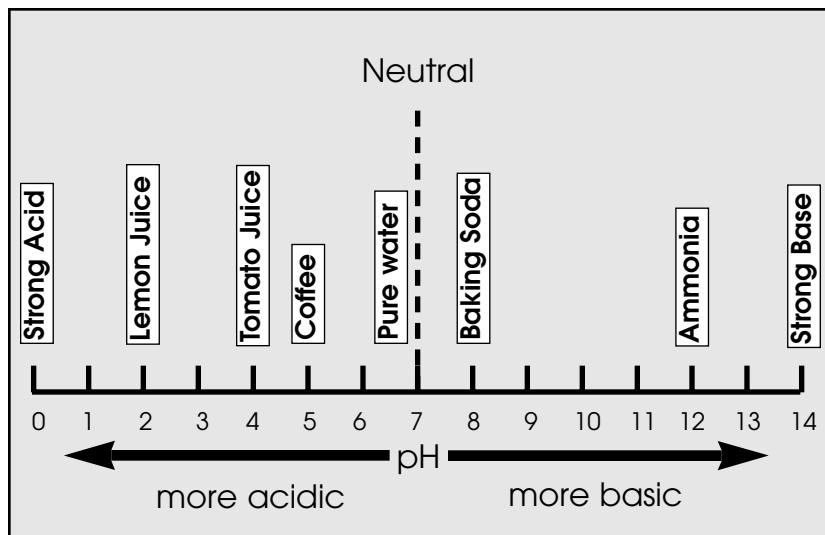
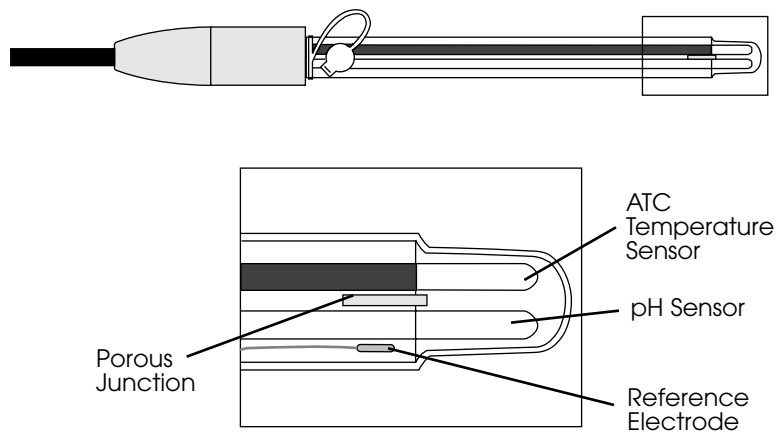

Figure 1.
pH Scale showing the relative acidity or basicity of some common substances.

Measuring pH

To measure pH with a conventional glass pH electrode, the meter uses a pH-sensing glass bulb that is sensitive to hydrogen ions. The potential developed at the glass membrane is directly related to the pH of the solution.

The glass electrode is paired with a reference electrode which completes the electrical measuring circuit and provides a stable reference point. These two electrodes are joined to create a combination electrode. The combination glass electrode is connected to the pH meter which reads the voltage, converts it to pH units, and displays the result.



Combination Glass pH Electrode

This meter can also use the Denver Instrument Field Effect Transistor (FET) electrode for measuring pH. The FET uses an ion-sensitive solid state membrane attached to the transistor to measure the hydrogen ion concentration of a solution. The FET is paired with a reference electrode that maintains a constant potential while the FET responds to the sample.

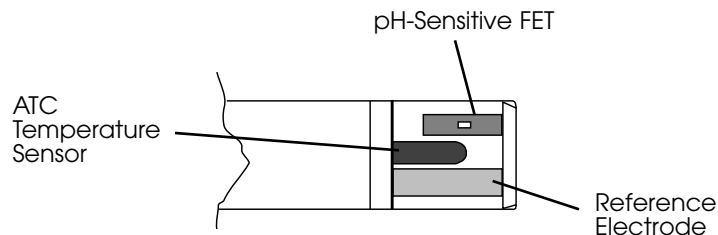

Troubleshooting

1. If the signal from the electrode is *out of range*, the display will show Err. This may happen when the electrode is not in a solution.

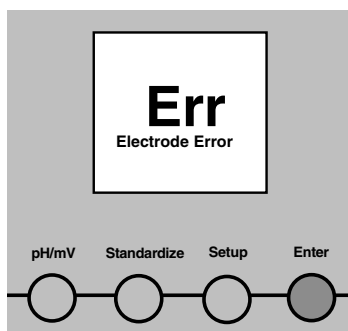

2. The meter will display *Electrode Error* when it detects an error in electrode response. During standardization, the message indicates that the electrode is less than 90% or more than 105% of the correct response. The *Electrode Error* message can indicate either a bad electrode or bad buffer(s).

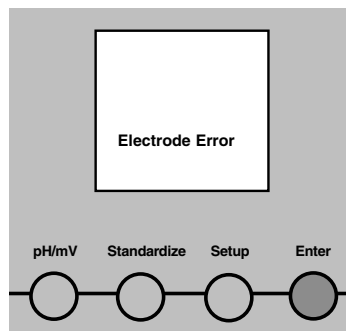

3. If the meter detects an error in the temperature probe, the display shows *Err°C*. If you do not use a temperature probe, the meter uses the default temperature that you set, either 20°C or 25°C.

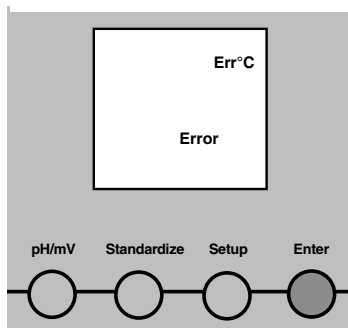

4. To test the pH electrode, place it in a good pH 7 buffer. Press **pH/mV** to use the mV mode, and note the millivolt reading. Make sure the meter is in mV mode and not relative mV mode. Repeat for either a pH 4 or pH 10 buffer. The electrode signal must be within the limits shown below (when temperature is near 25°C).

Electrode Test

pH 7 0 ± 30 mV

pH 4 159 to 186 mV
more than pH 7

pH10 159 to 186 mV
less than pH 7

5. To test the meter for correct operation, install the BNC (input) shorting cap. Press **pH/mV** to select the mV mode, and note the mV reading. Make sure the meter is in mV mode and not relative mV mode. If the meter reads 0 ± 0.3 mV, it is measuring correctly. Note that a long term drift of 0.1mV/month since last calibration is specified.

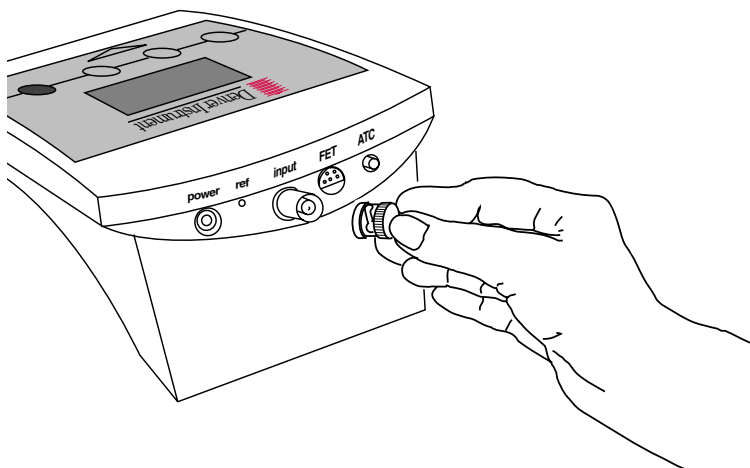

6. If the meter detects a loss of calibration or a hardware error during its power-up self-test, the display shows **CAL Error**. This means the mV accuracy may be reduced, but pH accuracy after standardization will be the same. Press **Enter** to continue using the meter. If recalibration is desired, contact Technical Support.

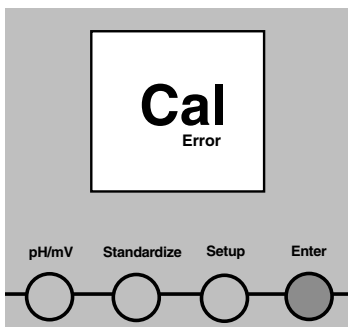

Accessories

You can order the following accessories for your pH meter:

Plastic-body pH/ATC Electrode	300728.1
High-performance glass-body pH/ATC Electrode	300729.1
Denver FET pH/ATC Electrode	300486.1
ATC Temperature Probe	300733.1
Free-standing Electrode Arm with Base	300401.1
Meter Lock-down Device	36800110.1

Other electrodes, such as ion selective electrodes and redox electrodes are also available. Call your sales representative.

Meter Specifications

pH	-1.99 to 19.99 pH displayed to 0.01 pH accurate to 0.01 pH
mV	-1800.0 to 1800.0 mV displayed to 0.1 mV accurate to 0.3 mV
Temperature	-5.0 to 105.0°C displayed to 0.1°C accurate to 0.4°C
Standardization	0, 1, 2 or 3 buffers
Auto buffer recognition	22 buffers 2, 4, 7, 10, 12 1, 3, 6, 8, 10, 13 1.68, 4.0, 6.86, 9.18, 12.46 1.09, 3.06, 4.65, 6.79, 9.23, 12.75

Auto Temperature Compensation
Automatic electrode slope correction for 90-105%
Direct reading with both a glass and FET pH electrode

Technical Assistance and Return Shipping Instructions

Please return the prepaid, pre-addressed Purchase registration Card to the manufacturer promptly upon your purchase of the product. The return of the card is not a condition precedent to warranty coverage.

Contact your local distributor to determine a solution to the problem. If further technical assistance is needed, contact Technical support in:

North America – Tel: 1-800-321-1135 or Fax: 303-423-4831
United Kingdom – Tel: (0366) 386242 or Fax: (0366) 386204

- A Return Authorization Number from Customer Service is required for all returned units.
- Write a detailed description of the unit's malfunction on the packing slip.
- Unplug and remove the power supply
- Place the pH meter and power supply in the original shipping carton. Secure the unit with the original packing material. If the original packing is not available, call the Customer Service number. **The factory packing material must be used!**
- Enclose the packing slip.
- Close the carton and secure with appropriate packing tape.
- Write the Return Authorization number on the outside of the carton.

In the U.S. ship to:

**Denver Instrument Company
6542 Fig Street
Arvada, Colorado 80004**

In the U.K. and Europe ship to:

**Denver Instrument Company, Ltd.
Denver House, Sovereign Way
Trafalgar Business Park, Downham Market
Norfolk PE38 9SW England**

Upon receipt and inspection of the defective unit, we will promptly repair or replace the product. Units which have not been maintained in accordance with the operating instructions, or have been misused or abused, will be repaired and returned with service charges due.

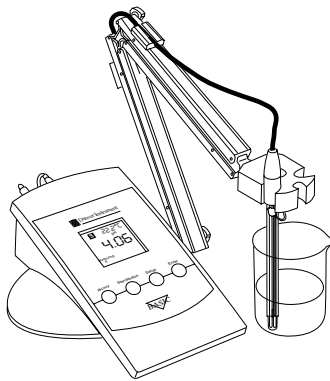

 **Denver Instrument Company**

6542 Fig Street • Arvada, Colorado 80004 U.S.A.
1-800-321-1135 • (303) 431-7255 • Fax (303) 423-4831

www.denverinstrument.com

European Office:

Denver Instrument Company, Ltd.
Denver House, Sovereign Way • Trafalgar Business Park
Downham Market. Norfolk PE38 9SW • England